

We offer the widest range of high-speed digitizers available on the market today. Our powerful PC-based instrumentation products allow you to create reliable, flexible and high-performance solutions quickly and easily.

Reduce development time and costs for testing complex applications such as radar, wireless communications, spectroscopy, etc. by using our GageScope software or SDKs.

APPLICATIONS

Spectroscopy
Radar System Design and Test
Signal Intelligence
Lidar Systems
Wireless Comm
Non-Destructive Testing
High-Performance Imaging
Manufacturing Test

CompuScope 14200

General-purpose digitizer for the PCI bus



A general-purpose, high-resolution digitizer with the power to satisfy the most demanding precision measurement requirements.

FEATURES

- 200 MS/s sampling on 2 synchronous channels
- 14 bits nominal resolution
- 100 MHz bandwidth
- Full-size, single-slot PCI card
- Now available with up to 2 GigaSamples of on-board acquisition memory!
- Full-featured, software-controlled front-end
- 32 bits, 66 MHz PCI standard for 200 MB/s transfer to PC memory
- Programming-free operation with GageScope oscilloscope software
- Software Development Kits available for LabVIEW, MATLAB, C/C#

CompuScope 14200 Simplified Block Diagram

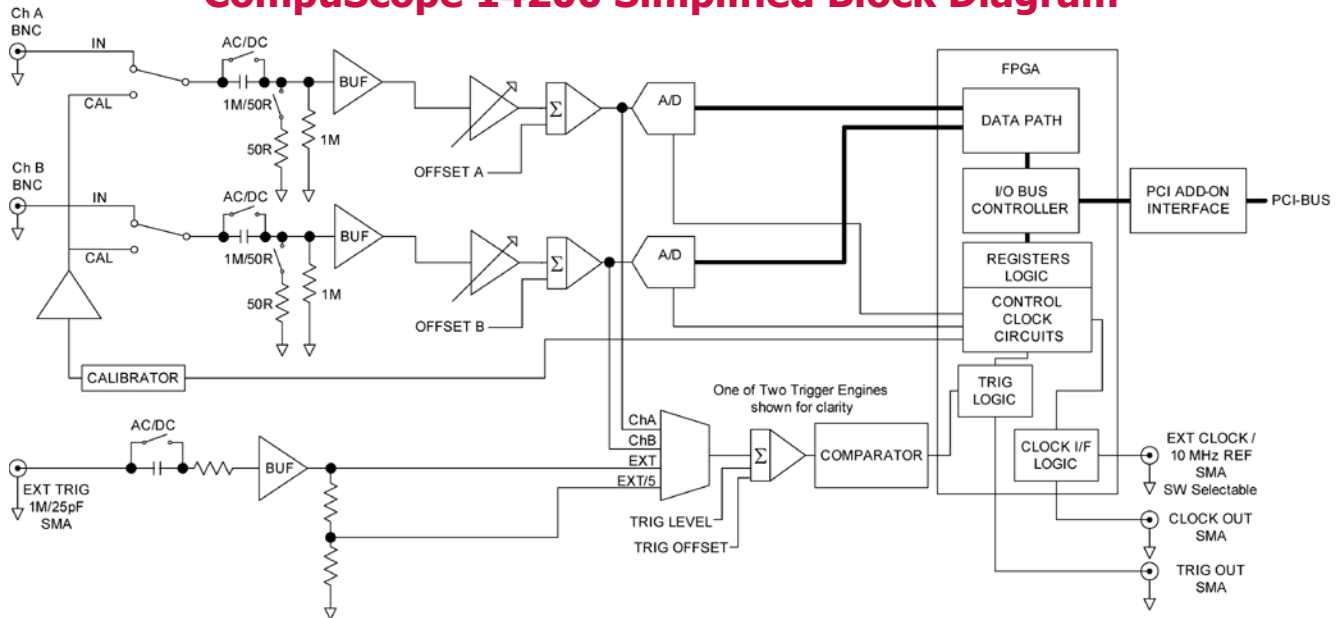

A/D SAMPLING

| | |
|---|---|
| Number of Inputs: | 2 |
| Resolution: | 14 bits |
| ENOB (see Note 1): | 10.7 bits |
| SNR (see Note 1): | 66 dB |
| SFDR (see Note 1): | 71 dB |
| SINAD (see Note 1): | 64 dB |
| Sampling Rates, Channels A and B simultaneously, or A only: | 200 MS/s, 160 MS/s, 100 MS/s, 80 MS/s, 50 MS/s, 40 MS/s, 25 MS/s, 20 MS/s, 10 MS/s, 5 MS/s, 2 MS/s, 1 MS/s, 500 kS/s, 200 kS/s, 100 kS/s, 50 kS/s |
| Connector: | BNC |
| Impedance: | 1 M Ω 40 pF or 50 Ω ; (software-selectable) |
| Coupling: | AC or DC; (software-selectable) |
| AC Coupled Bandwidth: | 10 Hz to 100 MHz (see Note 2) |
| DC Coupled Bandwidth: | DC to 100 MHz (50 Ω only, slightly less for 1 M Ω) |
| Flatness (see Note 2): | Within 1 dB of ideal response over 75% of bandwidth |
| DC Accuracy: | ± 0.5 % |
| Input Voltage Ranges: | ± 100 mV, ± 200 mV, ± 500 mV, ± 1 V, ± 2 V, ± 5 V (± 5 V is only available in 50 Ω) |
| DC Offset: | $\pm 1 \times$ Full Range, except in ± 5 V input range |
| Protection: | with 1 M Ω impedance: Diode-clamped with 50 Ω impedance: No protection |
| Absolute Maximum Amplitude | |
| with 1 M Ω impedance: | ± 15 V (continuous) |
| with 50 Ω impedance: | ± 5 V (continuous); ± 15 V (for 1 ms duration) |

DIRECT-TO-ADC SAMPLING MODE

| | |
|-----------------------|--|
| Mode Control: | Software-selectable |
| AC Coupled Bandwidth: | 30 kHz to 75 MHz (50 Ω , AC only; see Note 2) |
| Range: | ± 500 mV |

| | |
|-----------------------------|---|
| Protection: | No protection |
| Absolute Maximum Amplitude: | ± 2 V (continuous) ± 4 V (for 1 ms duration) |
| Sample Rate: | ≤ 100 MS/s |

ACQUISITION MEMORY

| | |
|---------------------------------------|--|
| Data Storage: | In on-board memory |
| Memory Depth per Channel: | 16M, 64M, 512M, 1G (14-bit samples in 16-bit words) |
| One-Channel Mode (Channel A only): | Up to 2G (Up to full on-board memory) |

TRIGGERING

| | |
|-------------------------|---|
| Trigger Engines: | 2 per system |
| Source: | CH A, CH B, EXT or Software |
| Input Combination: | 1, 2, 1 or 2 |
| Type: | Analog triggering |
| Trigger Level Accuracy: | ± 5 % of Full Scale |
| Slope: | Positive or Negative; software-selectable |
| Sensitivity: | ± 10 % of Full Scale This implies that signal amplitude must be at least 20% of full scale to cause a trigger to occur. Smaller signals are rejected as noise. |
| Post-Trigger Data: | 128 points minimum. Can be defined with a 64 point resolution. |
| Maximum Record Length: | Maximum memory depth |

EXTERNAL TRIGGER

| | |
|----------------|--|
| Impedance: | 1 M Ω , 35 pF |
| Amplitude: | Absolute maximum ± 15 V |
| Voltage Range: | ± 1 V, ± 5 V (software-selectable) |
| Bandwidth: | 80 MHz |
| Coupling: | AC or DC |
| Connector: | SMA |

TRIGGER OUT

Impedance: 50 Ω
Amplitude: 0-2.5 V (TTL)
Connector: SMA

INTERNAL CLOCK

Source: Clock oscillator
Accuracy: ± 25 ppm (0 to 50°C ambient)

EXTERNAL CLOCK

Maximum Frequency: 200 MHz
Minimum Frequency: 1 MHz
Signal Level: Minimum 1 V RMS
Maximum 2 V RMS
Termination Impedance: 50 Ω
Sampling Edge: Rising
Duty Cycle: 50% \pm 5%
Connector: SMA
Coupling: AC

EXTERNAL REFERENCE

The External Reference timebase is used to synchronize the Internal Sampling Clock

Frequency: 10 MHz; (software-selectable)
Signal Level: Minimum 1 V RMS
Maximum 2 V RMS
Impedance: 50 Ω
Sampling Edge: Rising
Duty Cycle: 50% \pm 5%
Connector: SMA

CLOCK OUT

Maximum Frequency: 100 MHz
Minimum Frequency: 1 MHz (from External Clock)
50 kHz (from Internal Clock)
Output Frequency: Equal to the sample rate when it is ≤ 100 MS/s
Equal to half the sample rate when it is > 100 MS/s
Signal Level: 0-2.5 V (TTL)
Impedance: 50 Ω
Duty Cycle: 50% \pm 10%
Connector: SMA

MULTIPLE RECORD

Pre-trigger Data: Up to virtually full record length
Record Length: 128 points minimum.
Can be defined with a 64 points resolution.
Maximum # Trigger: 8,388,608

MULTI-CARD SYSTEMS

A unique feature of the CS14200 is its ability to automatically reconfigure itself to Master/Slave or Independent multi-card system simply by adding or removing the Master/Slave Timing Module.

Operating Mode: Master/Slave or Multiple/Independent configurations
Master/Slave: 2 to 8 cards
Multiple/Independent: Limited by PC backplane

TIMESTAMPING

Resolution: 7.5 ns
Counter turnover: 24 hours continuous

CARD SIZE

Single-slot, full-length PCI

SYSTEM REQUIREMENTS

PCI-based computer, minimum Pentium II 500 MHz, with at least one free full-length PCI slot, 128 MB RAM, 100 MB hard disk.

COOLING SYSTEM

Minimum CFM Requirement: *Characterization in progress*

POWER (IN WATTS, PER CARD)

| +5 V | | |
|-------------------|-------|---------|
| | Worst | Typical |
| All Memory Depths | 18.25 | 18.25 |
| +3.3 V | | |
| | Worst | Typical |
| All Memory Depths | 6.67 | 6.67 |
| +12 V | | |
| | Worst | Typical |
| All Memory Depths | 0 | 0 |
| -12 V | | |
| | Worst | Typical |
| All Memory Depths | 0 | 0 |

PCI BUS INTERFACE

Plug-&-Play: Fully supported
Bus Mastering: Fully supported
Scatter-Gather: Fully supported
Bus Width: 32 bits
Bus Speed: 66 MHz or 33 MHz
Bus Throughput: 200 MB/s to PC memory (66 MHz PCI; dependent on motherboard and number of PCI-PCI bridges)
Compatibility: PCI-compliant, v.2.2
Also v.2.1 systems that supply 3.3 V to PCI slot

OPERATING SYSTEMS

Windows XP: All Versions
Windows 2000: SP1 or higher

APPLICATION SOFTWARE

GageScope: Windows-based software for programming-free operation
LITE Edition: Included with purchase, provides basic functionality
Standard Edition: Provides limited functionality of advanced analysis tools, except for Extended Math
Professional Edition: Provides full functionality of all advanced analysis tools



SOFTWARE DEVELOPMENT KITS (SDK)

CompuScope SDK for C/C# for Windows*
CompuScope SDK for MATLAB for Windows
CompuScope SDK for LabVIEW for Windows

*C/C# SDK is compatible with LabWindows/CVI 7.0+ compiler.
Visual Basic.NET support available with purchase of C/C# SDK.

Contact your Gage Sales Agent for information on Linux support.

WARRANTY

One year parts and labor
Certificate of NIST Traceable Calibration is included.

All specifications subject to change without notice.

Notes to specifications:

- 1) Unless otherwise specified, all dynamic performance specs (ENOB, SNR, SFDR, SINAD) are measured at 9.85 MHz with an Input Amplitude of 95% of Full Scale in Direct-to-ADC mode and sampling at 80 MS/s.
- 2) Detailed characterization curves will be available upon request.

ORDERING INFORMATION

Hardware & Upgrades

| | |
|------------------------------------|-----------------|
| CompuScope 14200-32M | 142-001-002 |
| CompuScope 14200-128M | 142-001-004 |
| CompuScope 14200-1G | 142-001-006 |
| CompuScope 14200-2G | 142-001-007 |
| CS14200: Memory Upgrades | Contact Factory |
| CS14200: Master Multi-Card Upgrade | 142-181-002 |
| CS14200: Slave Multi-Card Upgrade | 142-181-003 |

eXpert™ Firmware Options

| | |
|---|-------------|
| eXpert Signal Averaging Firmware Option | 250-181-001 |
| eXpert FIR Filtering Firmware Option | 250-181-002 |
| eXpert Peak Detection Firmware Option | 250-181-003 |
| eXpert Firmware Option bundle (Signal Averaging, FIR Filtering and Peak Detection) | 888-100-026 |

GageScope® Software

| | |
|---|-------------|
| GageScope: Lite Edition | Included |
| GageScope: Standard Edition (with Purchase of CompuScope Hardware) | 300-100-351 |
| GageScope: Professional Edition (with Purchase of CompuScope Hardware) | 300-100-354 |

Software Development Kits (SDKs)

| | |
|----------------------------|-------------|
| Gage SDK Pack on CD | 200-113-000 |
| CompuScope SDK for C/C# | 200-200-101 |
| CompuScope SDK for MATLAB | 200-200-102 |
| CompuScope SDK for LabVIEW | 200-200-103 |

All Upgrades performed at the factory.

900 N. State St.
Lockport, IL 60441-2200

Toll-Free (US and Canada):

phone 1-800-567-4243
fax 1-800-780-8411

Direct:

phone +1-514-633-7447
fax +1-514-633-0770

Email:

prodinfo@gage-applied.com

To find your local sales representative
or distributor or to learn more about
Gage's products visit:

www.gage-applied.com

Updated July 24th, 2006

Copyright © 2004, 2005, 2006 Gage Applied Technologies. All rights reserved.