

Use of a PC-Based Digitizer in an Ultrasonic Flaw-Detection System

Written by: Andrew Dawson, Ph.D.

ABSTRACT: Use of modern high-speed digitizers in the construction of an ultrasonic flaw detection system is discussed. Topics include the advantages of high sampling speed, high vertical resolution, deep acquisition memory buffers, and fast data transfer speed to the host PC. Issues that arise due to the Windows operating system are also addressed.

A company manufactures complete ultrasonic flaw detection systems that are used for the non-destructive testing of laminar steel parts, principally for the detection of embedded defects. Their current system performs all measurements using analog circuitry. The company's manufacturing engineer would like to produce a modernized PC-based system that provides higher performance at a lower cost.

A commercial broadband ultrasonic transducer is robotically positioned in front of a part under test, all of which is immersed in a water tank. The transducer is operated in reflection mode, where it is used to both generate and detect ultrasound. Excited by an ultrasonic pulser/receiver unit, the transducer emits a wideband burst of ultrasonic energy and then receives echoes reflected off of the part.

In between successive ultrasonic record acquisitions, a robotic positioning arm that is controlled through a GPIB connection laterally displaces the transducer in 0.1 mm steps. The arm scans through a 500 mm × 500 mm rectangular mesh in a back-and-forth, grill-like pattern, so that there is a "fast" and an orthogonal "slow" axis. While the transducer is translating along the fast axis, the positioning system continuously displaces the transducer in a step-like fashion at a regular rate of about 1 step per millisecond.

The position controller is equipped with a "Pulse On Position" output. This is a standard feature of many position controllers used in ultrasonics. The controller produces a TTL pulse at the instant when it has stabilized at its target position. This pulse is used to trigger the ultrasonic pulser/receiver to emit an excitation pulse. In this way, ultrasonic inspection is automatically performed only at the target position. In the engineer's configuration, the pulser/receiver will produce triggers at a regular rate of 1 kHz.

The engineer requires an embedded digitizer to capture ultrasonic signals from the transducer electronics. Since the system uses ultrasonic transducers with center frequencies of up to 10 MHz, the engineer wishes to sample the ultrasonic signals at 100 MegaSamples per second (MS/s). This sampling rate provides 10 points per signal cycle, which allows excellent echo

timing resolution. Since the engineer wants to detect flaw echoes that are as small as possible, the highest available dynamic range and vertical resolution are required.

After excitation of the transducer, the relevant ultrasonic echo trains take about 700 μ s to return, since the ultrasound must traverse a meter-long water path. A programmable *Delay Gate* is used to create a TTL pulse that occurs 700 μ s after the ultrasonic excitation. This pulse is used to trigger the digitizer. The ultrasonic echo trains of interest then occur over a period of up to 100 μ s.

The engineer would like to write a controlling application in the C programming language under Windows 2000 that controls both the positioning system and the digitizer.

Gage's solution to the requirement is the CompuScope 14100 – a PC-based digitizer card for the PCI bus. The digitizer card provides the 100 MHz sampling rate and ample 50 MHz input analog bandwidth that is required by the speed of the ultrasonic transducer. Figure 1 is a schematic diagram of the entire system.

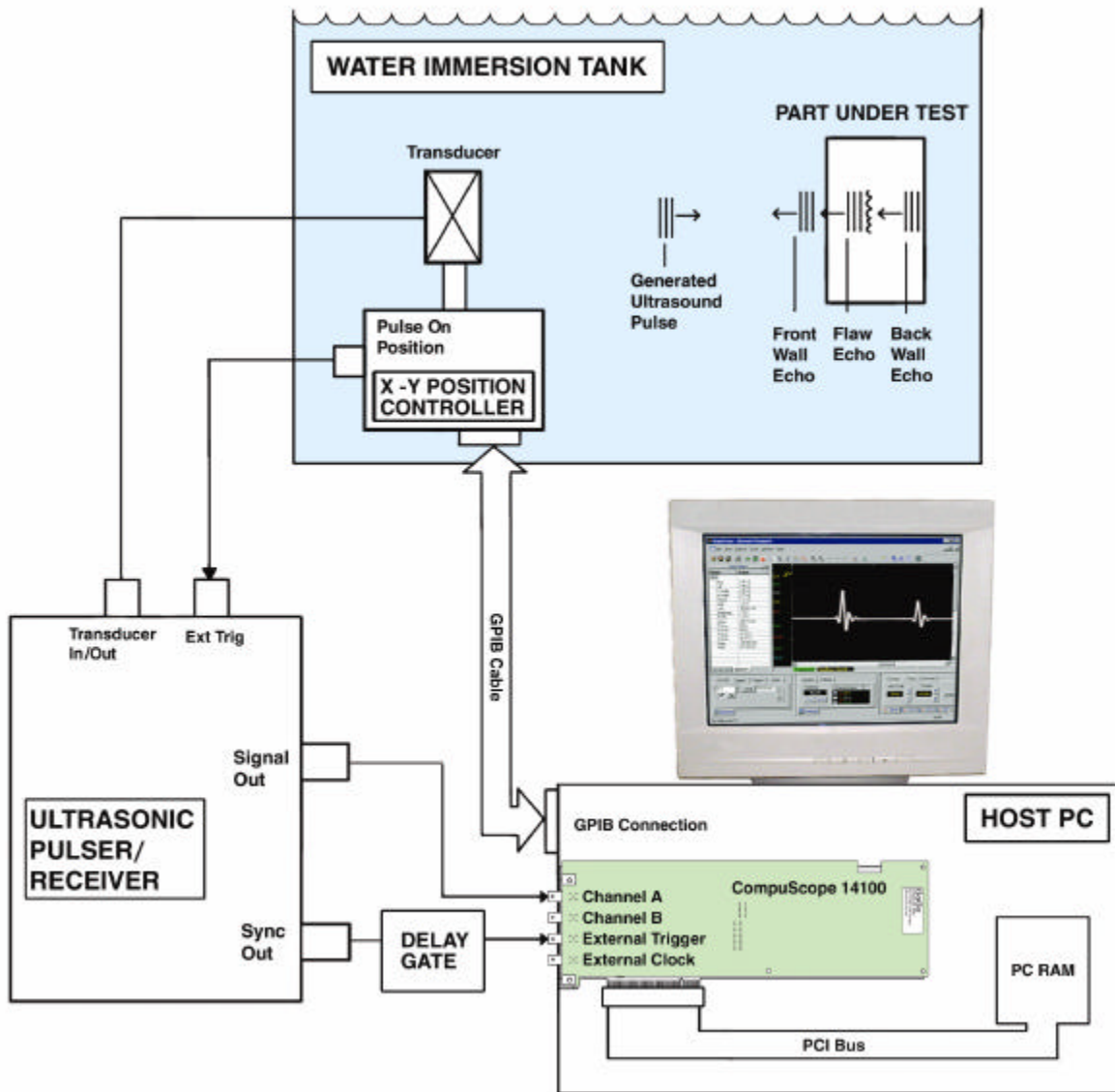

Figure 1: Schematic diagram of an ultrasonic flaw detection system

The ± 1 Volt signal output from the ultrasonic pulser/receiver is connected directly to the signal input of the digitizer card on its convenient BNC input connector. A digitizer input impedance of 50Ω can be programmatically selected. This provides input termination that matches the 50Ω impedance of the BNC cable, thus eliminating distortions due to multiple signal reflections. The output of the Delay Gate is connected to the BNC External Trigger input of the digitizer.

The digitizer provides 14 bits of vertical sampling resolution. High vertical resolution is imperative in ultrasonic non-destructive testing because of the arbitrarily small amplitude of detected flaw echoes. Figure 2A shows a real ultrasonic signal detected from a laminar steel part. The curve shows the large echo reflected from the front-wall of the part followed by a small echo that indicates a flaw just below the surface. The time by which this flaw echo trails the front-wall echo (Δt) is directly related to the *depth* of the flaw through the relation:

$$depth = \frac{v \Delta t}{2}$$

where v is the velocity of ultrasound in steel. One goal of the ultrasonic scan is to determine Δt throughout the scan and to produce a color-coded map indicating flaw depths throughout the part.

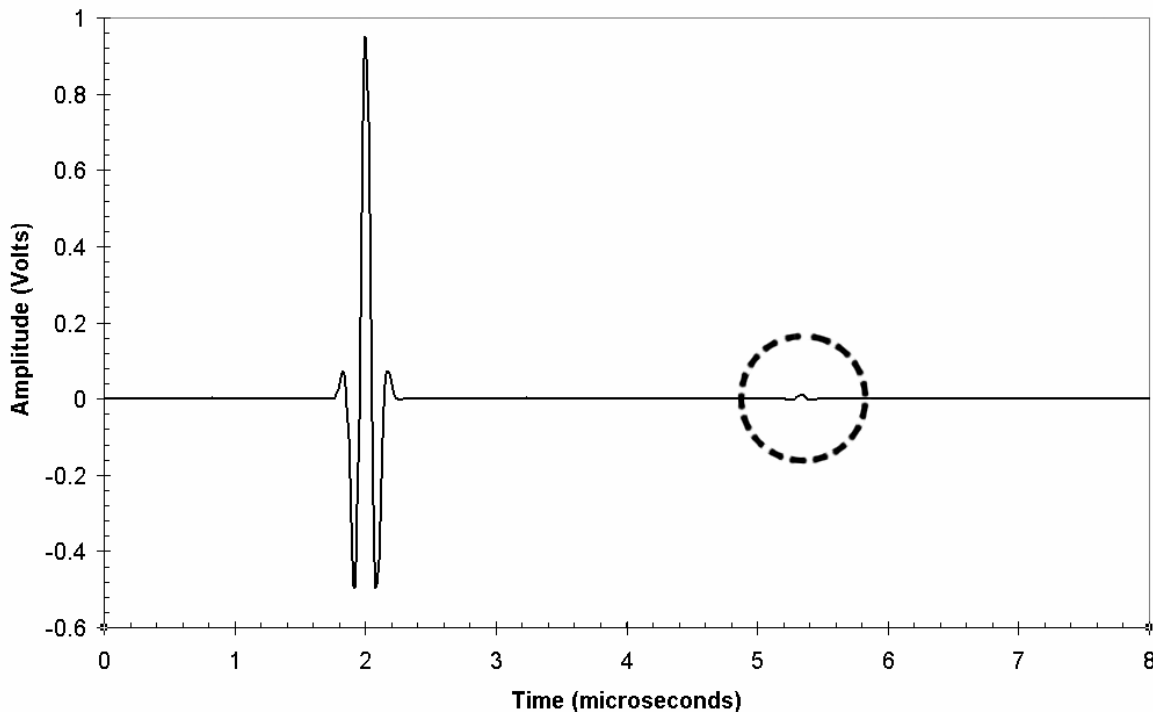

Figure 2A: Ultrasonic signal captured after reflection off a laminar steel part. A small flaw echo is circled.

The amplitude of the trailing echo grows with the size of the flaw. The overall ultrasonic signal amplitude is adjusted using the gain control of the pulser/receiver so that the front-wall echo almost saturates the input range of the digitizer - in this case ± 1 Volt. The small flaw echoes therefore cannot be further amplified without clipping the front-wall echo. Figure 2B shows a magnified view of the small flaw echo from Figure 2A. The echo is shown as captured by a digitizer with 8-bit resolution - the highest available for many 100 MS/s digitizers. The same echo is also shown as captured by the 14-bit digitizer.

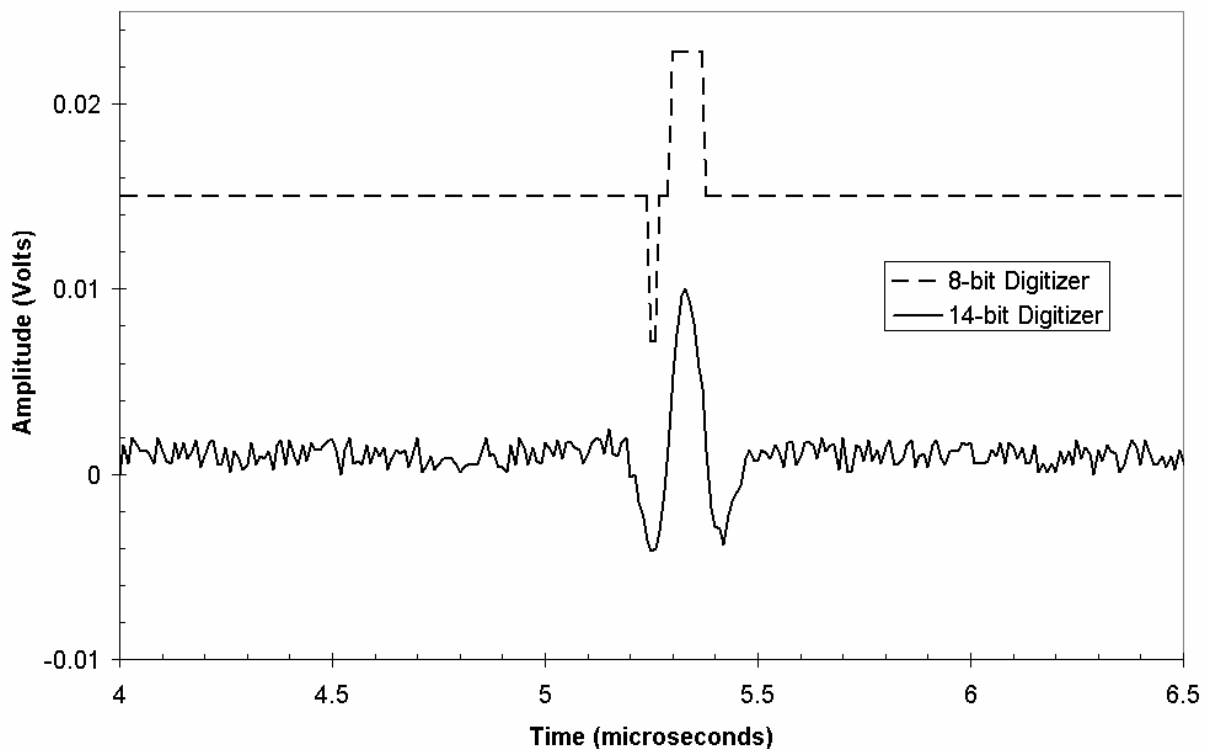

Figure 2B: Magnification of circled flaw echo from Figure 2A. Waveforms captured with an 8-bit digitizer and with the 14-bit digitizer are shown.

The amplitude of the flaw echo is only about 1% of the amplitude of the large front-wall echo. The 8-bit digitizer divides the input range into $2^8 = 256$ different levels. This explains the step-like appearance of the 8-bit echo from Figure 2B, which only spans two or three levels. The echo is obviously severely distorted and if it were any smaller, would not have been detected at all.

By contrast, the 14-bit digitizer divides the input range into $2^{14} = 16,384$ different levels. The flaw echo now spans over 150 levels. It is obvious from Figure 2B that the 14-bit digitizer's

high resolution faithfully reproduces the form and position of the small echo. Even if the echo were comparable to the background noise, its time-delay, Δt , could still be extracted using numerical cross-correlation analysis. Clearly, high digitizer resolution is crucial for the detection of small flaw echoes.

During linear scans along the fast axis, ultrasonic triggers occur at a regular 1 kHz rate. The digitizer must not miss any of these triggers otherwise correspondence between captured waveforms and transducer position will be lost.

Linear scans along the fast-axis take $(500 \text{ mm} / 0.1 \text{ mm}) / 1 \text{ kHz} = 5 \text{ seconds}$. Initiation of the next fast-axis scan is under programmatic control. However, for mechanical reasons, repositioning of the slow-axis motor must take at least 0.5 seconds.

The 14-bit digitizer is capable of transferring data through the PCI bus at sustained rates of up to 100 MegaBytes per second. Consequently, the digitizer is fully capable of capturing 50 μs ultrasonic waveforms and transferring them through the PCI bus to PC RAM in ample time to prepare for the next 1 kHz trigger. The 14-bit digitizer easily meets this performance benchmark under a single-tasking Operating System, such as MS-DOS.

A problem occurs, however, with operation under MS Windows. Multi-tasking Windows is not a Real Time Operating System (RT O/S). Consequently, the amount of time during which a given task or process is interrupted while Windows services other tasks is indeterminate. As a result, no repetitive waveform capture performance can be guaranteed under Windows. Guaranteed, reliable performance is paramount during the system's fast-axis scan, where not even a single trigger can be missed.

The solution to the requirement for reliable performance under Windows is ultra-deep on-board acquisition memory. The engineer can then operate the digitizer in Multiple Record mode. In this mode, successively acquired waveforms are stacked in on-board acquisition memory. Between acquisitions, the digitizer is re-armed almost instantaneously by the hardware with no CPU intervention required. Consequently, once initiated, Multiple Record mode operates in a completely reliable fashion that is not compromised by the multi-tasking Windows environment.

The digitizer will require enough on-board acquisition memory to hold data from an entire fast-axis scan. In order to determine the amount of memory required, we must first calculate the number of samples in a single 100 μs ultrasonic record:

$$\begin{aligned} \text{Record Length} &= 100 \text{ } \mu\text{s} \times 100 \text{ MS/s} \\ &= 10,000 \text{ S} = 10 \text{ kS} \end{aligned}$$

Since the position step size is 0.1 mm and since the fast axis length is 500 mm, there are 5,000 position steps in one linear fast axis scan. The digitizer must capture one 10,000-sample record per position step. The on-board acquisition memory must therefore be at least:

$$5,000 \text{ Records} \times 10,000 \text{ Samples/Record} = 50,000,000 \text{ Samples.}$$

The CompuScope 14100 is available with up to 1 GigaSample of on-board acquisition memory. The appropriate choice for this requirement is 64 MegaSamples.

Between successive fast-axis scans, the system will download all of the data from the previous fast-axis scan to PC RAM. The digitizer is capable of rapidly transferring data through the PCI bus using a method called *PCI Bus Mastering*. Using this method, no CPU mediation is required during the data transfer and the digitizer can achieve sustained transfer rates of up to 100 MegaBytes/second. Since there are 2 Bytes per 14-bit sample, the transfer of all data from a fast-axis scan will take at least:

$$2 \text{ Bytes/Sample} \times 50,000,000 \text{ Samples} / (100 \text{ MegaBytes/second}) = 1 \text{ second}$$

Consequently, the data transfer will not drastically delay the onset of the next fast-axis scan, since the positioning system already requires 0.5 seconds of mechanical stabilization time. If the data transfer process is briefly interrupted by Windows, the transfer time increases slightly but no data are lost and, once reactivated, the transfer process simply picks up where it left off.

The engineer wrote a Windows 2000 based application in C using a Software Development Kit. This kit provides convenient, easy-to-use sample programs that serve as a starting point for a custom Windows application. Since the digitizer card is a PCI plug-n-play device, low-level configuration details are handled completely by Windows. No low-level hardware programming is required. The Windows application sets up the scan of the part under test, controls the positioning motors, and then calls C sub-routines to acquire and download data from the digitizer.

Today's high-performance PC-based digitizers provide the high sampling speed, high vertical resolution, deep acquisition memory and fast data transfer that allow easy construction of automated, low-cost NDT inspection systems.